

BRACKET BH3M

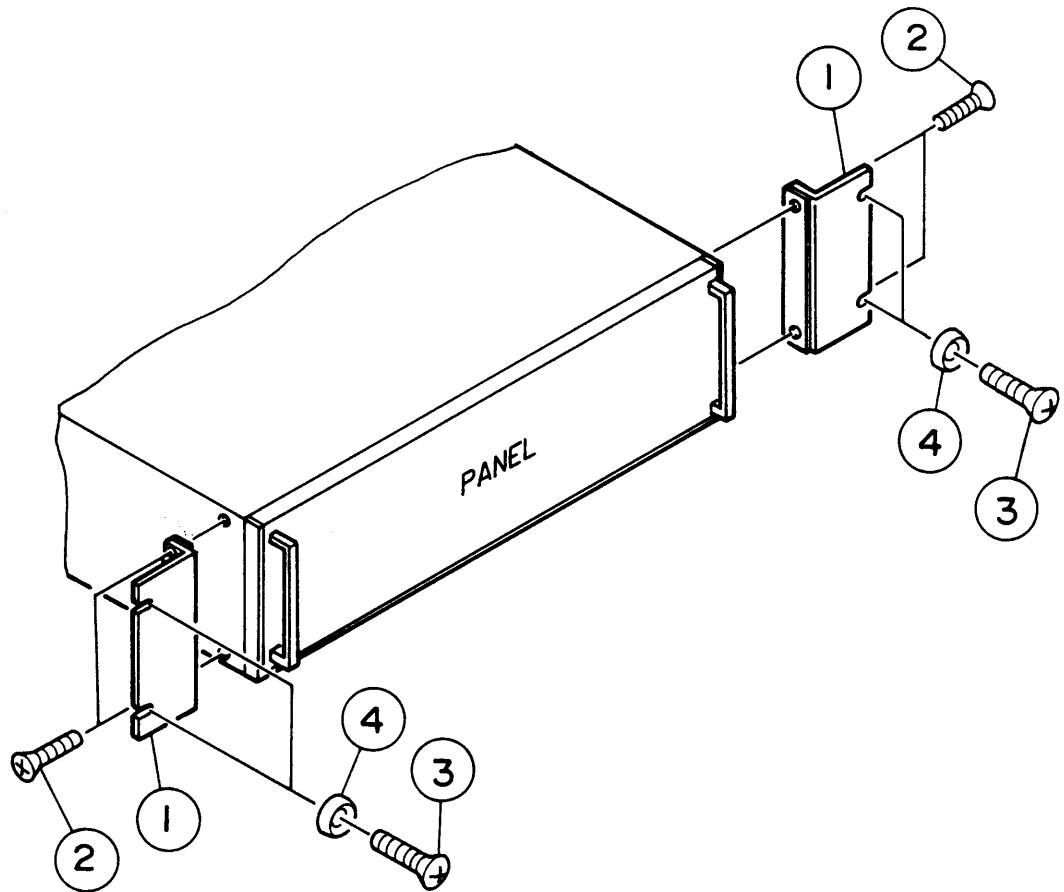

NO.	DESCRIPTION	QTY	CODE NO.
1	BRACKET BH3M	2	D3-924-801
2	SCREW, FLAT HEAD M4x0.7x16 S-ZN	4	M2-001-171
3	SCREW, OVAL HEAD M5x0.8x14 B-NI	4	M2-002-091
4	FINISHING WASHER 5CW	4	M5-003-031
2'	SCREW, FLAT HEAD M4x0.7x10 S-ZN (FOR PLZ700W ONLY)	4	M2-001-161